

Wiring diagram

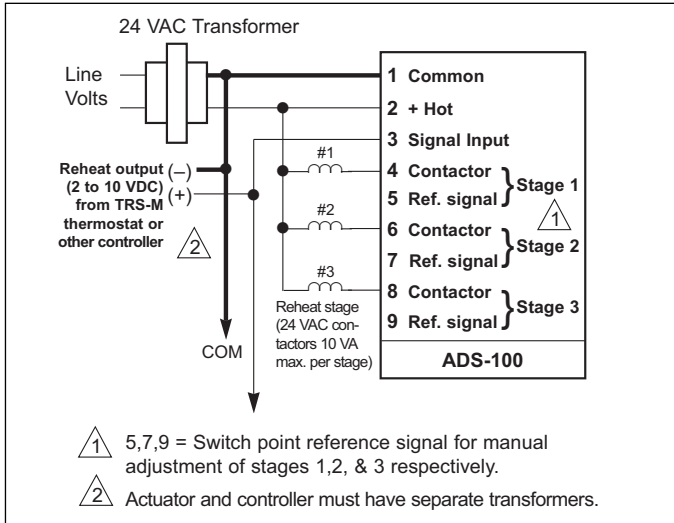

Application

To control reheat coils and/or a fan stage in a fan-powered terminal unit. The ADS-100 is controlled by a 2 to 10 VDC reheat output of a temperature controller. (TRS-M)

Operation

The ADS-100 is designed to switch up to three independent stages of reheat on and off, according to a 2 to 10 VDC signal. The three output stages are furnished with a triac output. Each stage can be adjusted independently from each other over the 0 to 2.4° F throttling range of the TRS-M temperature controller.

The ADS-100 is shipped pre-adjusted, as shown in the following table. (Based on differential from setpoint)

	1st. stage	2nd. stage	3rd. stage
Switch ON	-0.45°F	-1.35°F	-2.25°F
Switch OFF	-0.15°F	-1.05°F	-1.95°F
Switch ON	2.8V	5.8V	8.8V
Switch OFF	0.4V	0.2V	0.4V

If desired, each stage may be field readjusted for special requirements. Three red LED indicators are provided to verify when the stages are energized.

Setpoint readjustment

Tools required: small screwdriver, voltmeter.

To readjust the output stages, the following procedure is used: Connect the voltmeter to the desired switchpoint reference signal output and terminal 1 (COM). Readjust the switch point reference signal output with the corresponding potentiometer to your desired switch point. The adjustment range is 2.5 to 9.5 VDC. If you go below or above these values the ADS-100 may not switch off or on properly. If this occurs you have to increase or decrease your switching level until the ADS-100 works correctly.

Switchpoint adjustment drawings

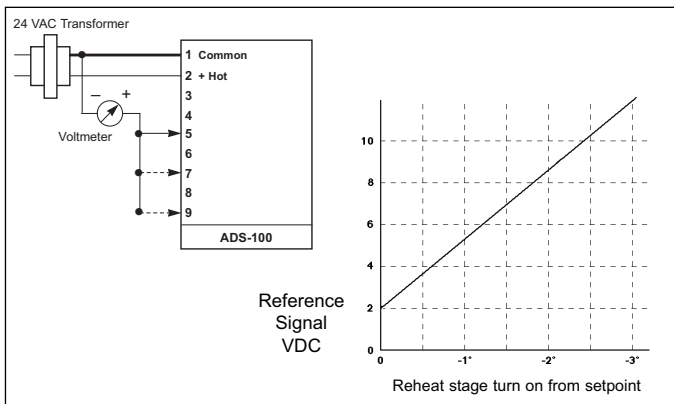

Technical Data	ADS-100
Power supply	24 VAC ± 20% 50/60 HZ
Power consumption	1.5 W
Transformer sizing	3 VA (not including contactors)
Electrical connection	9 pole wire-terminal
Control input	2 to 10 VDC
Input impedance	100 K Ω
Adjusting range	2.5 to 9.5 VDC
Dead band	0.3°F fixed
Switching capacity	24 VAC 10 VA max. (voltage sinking triac)
Mounting	Snap-Track (provided)
Dimensions	3 1/4" x 2" (3 7/16" x 2" w/snap-track)

ADS-100 used as an auxiliary switch

The ADS-100 was originally designed as an accessory to switch on stages of electric reheat from an electronic thermostat. However, it can also function as an electronic auxiliary switch from any device which can provide 0 to 10 VDC signal, such as any feedback wire 5 from any ...SR or ...MFT type actuator.

The ADS-100 has 3 triac outputs rated at 10 VA maximum each which will turn on, in sequence, with an increasing voltage.

Dimensions [All numbers in brackets are in millimeters.]

